



**SISTEMAS TUBULARES ALM  
ADVANCED LEAN MANUFACTURING**

# ALM

## **SISTEMAS TUBULARES ALM**

ADVANCED LEAN MANUFACTURING

### **COMPONENTES TUBULARES**

### **FABRICACIÓN DE EQUIPOS ESPECIALES**

SISTEMAS INDUSTRIALES ALM S DE RL DE CV , nuestra política de servicio es ofrecerle a nuestros clientes producto y servicio con la mejor calidad para mejora continua por lo cual ponemos a su consideración el siguiente catálogo de componentes en sistema tubulares de la marca Samsung así como nuestros servicios de fabricación.

Los sistemas tubulares ALM son la mejor herramienta para conseguir un flujo continuo en transferencia de materiales y en sistemas de almacenamiento para proporcionar facilidades a las líneas de producción cumpliendo con los criterios estandarizados de Lean Manufacturing.

Describiendo visualmente todos los componentes que contiene nuestro catálogo así como ayuda de información técnica y algunas aplicaciones fabricadas por nuestra empresa.

## ÍNDICE

- 1 PORTADA**
- 3 ÍNDICE**
- 4 SAMSUNG PIPE JOIN SYSTEM**
  - 5 TUBOS / PIPES**
  - 6 METAL JOINTS**
  - 9 METAL JOINT SET**
  - 12 METAL ACCESSORIES**
  - 15 BUSHINGS**
  - 16 ROLLER TRACKS**
  - 17 MOUNTING BRACKETS**
  - 19 PVC & PLATIC ACCESSORIES**
- 22 ALLUMINIUM PIPE SYSTEM**
- 25 CASTERS**
- 29 CATÁLOGO DE APLICACIONES**
- 32 FICHAS TÉCNICAS**





**ALM**

PIPE JOIN SYSTEM

## TUBOS

## PIPES



SSP2807-SS



SSP2810-SS



CP2810-G



CP2810-IV



CP2810-BK

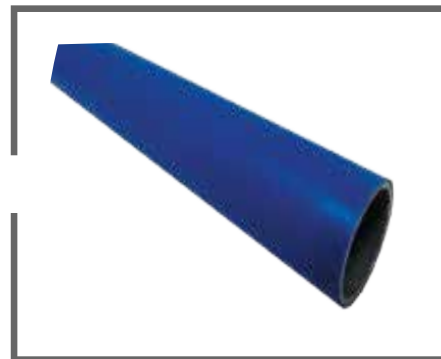

CP2810-BL

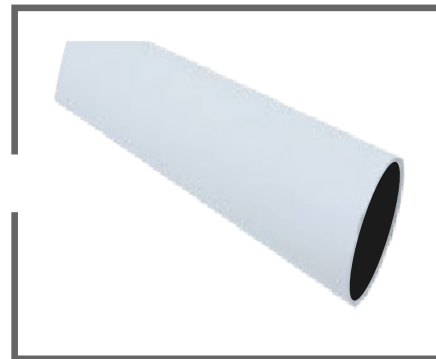

CP2810-WH

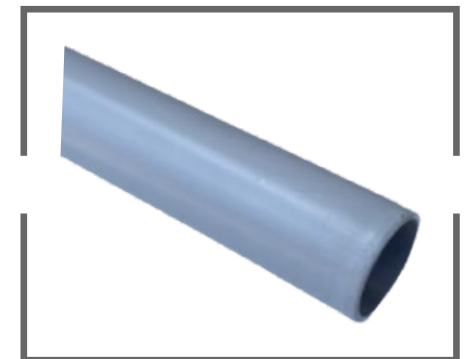

CP2810-LG

### Especificaciones:

- Recubrimiento: ABS
- Diam. Exterior: 28 mm
- Longitud: 4mts
- Espesor de 1.0 mm
- Acero Rolado en Frio
- Peso: 2.6 kg/Tramo
- Atado: 10 Tramos

### Restricciones:

ABS no usar a interperie, ambiente de soldadura, ni exponer a solventes o aceites solubles como thinner.

### COATED PIPES COLOR CODE

### COLOR CODE NUMBERING SYSTEM FOR COATED PIPES

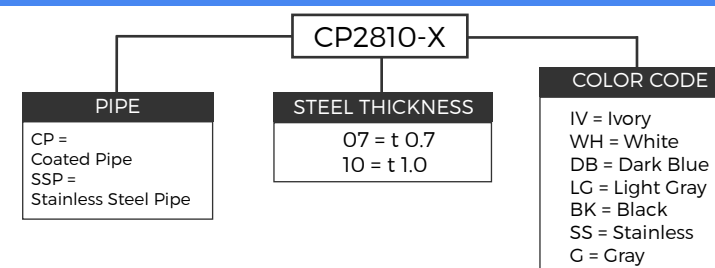

Lean Manufacturing

Servicios & Fabricación

Sistema Tubular ALM

TELS. 442 962 0149 - 442 236 4457 - 442 205 9989

✉ [ventas@sistemasalm.com](mailto:ventas@sistemasalm.com) ✉ [alm@sistemasalm.com](mailto:alm@sistemasalm.com) ✉ [sistemasindustrialesalm@gmail.com](mailto:sistemasindustrialesalm@gmail.com)



[www.sistemasalm.com](http://www.sistemasalm.com)

## METAL JOINTS

\*B = Black \*Z = Zinc



H-1



H-1A



H-2



H-3G (Gripe Type)



H-4



H-6



H-6A



H-7A



H-7B

## METAL JOINTS

\*B = Black \*Z = Zinc



H-8



H-10



H-11



H-12



H-13A



H-13B



H-14

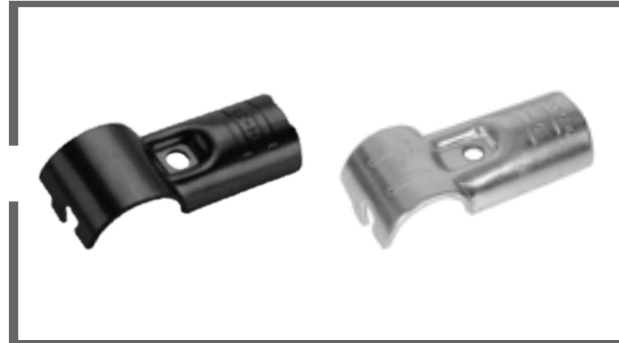

H-15



H-16

Lean Manufacturing

Servicios & Fabricación

Sistema Tubular ALM

TELS. 442 962 0149 - 442 236 4457 - 442 205 9989

✉ [ventas@sistemasalm.com](mailto:ventas@sistemasalm.com) ✉ [alm@sistemasalm.com](mailto:alm@sistemasalm.com) ✉ [sistemasindustrialesalm@gmail.com](mailto:sistemasindustrialesalm@gmail.com)

## METAL JOINTS

\*B = Black \*Z = Zinc



H-17



H-45



H-60



H-90

## METAL JOINT SET

\*B = Black \*Z = Zinc



HJ-1



HJ-1A



HJ-2

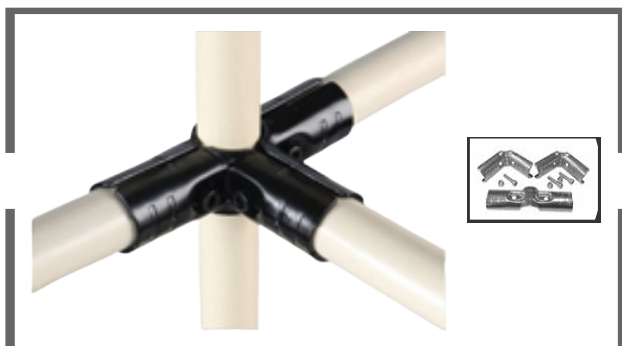

HJ-3



HJ-4



HJ-5



HJ-6



HJ-6A

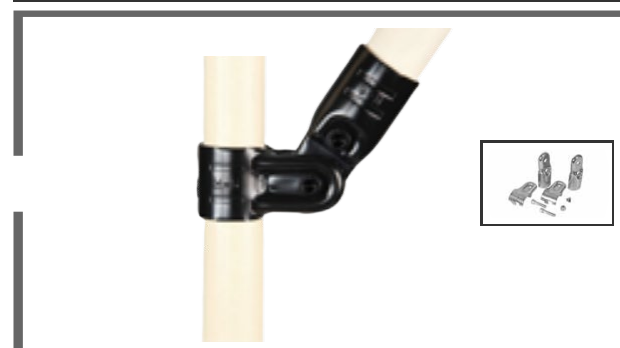

HJ-7

Lean Manufacturing

Servicios & Fabricación

Sistema Tubular ALM

TELS. 442 962 0149 - 442 236 4457 - 442 205 9989

✉ [ventas@sistemasalm.com](mailto:ventas@sistemasalm.com) ✉ [alm@sistemasalm.com](mailto:alm@sistemasalm.com) ✉ [sistemasindustrialesalm@gmail.com](mailto:sistemasindustrialesalm@gmail.com)

## METAL JOINT SET

\*B = Black \*Z = Zinc



HJ-8



HJ-10



HJ-11

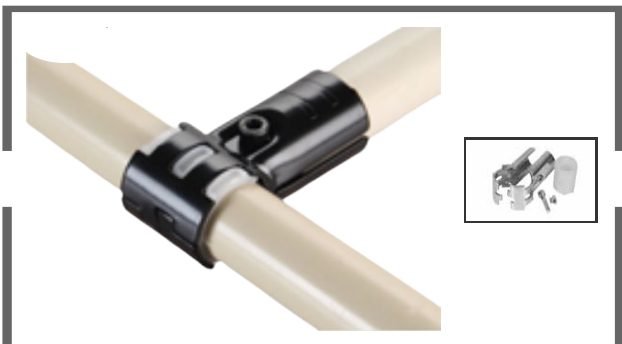

HJ-12

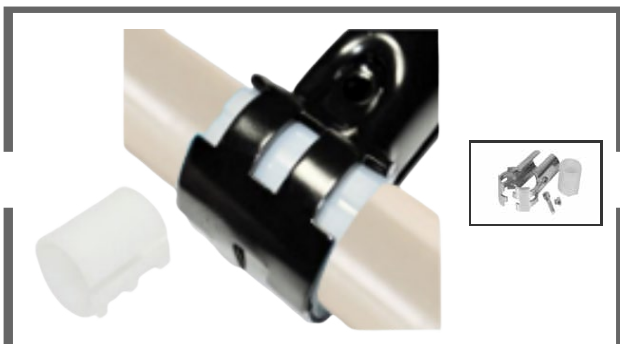

GAP 12

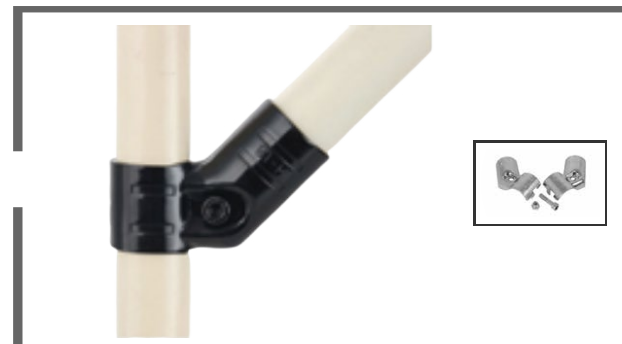

HJ-13B



HJ-14



HJ-15



HJ-16

Lean Manufacturing

Servicios & Fabricación

Sistema Tubular ALM

TELS. 442 962 0149 - 442 236 4457 - 442 205 9989

✉ [ventas@sistemasalm.com](mailto:ventas@sistemasalm.com) ✉ [alm@sistemasalm.com](mailto:alm@sistemasalm.com) ✉ [sistemasindustrialesalm@gmail.com](mailto:sistemasindustrialesalm@gmail.com)

[www.sistemasalm.com](http://www.sistemasalm.com)

## METAL JOINT SET

\*B = Black \*Z = Zinc

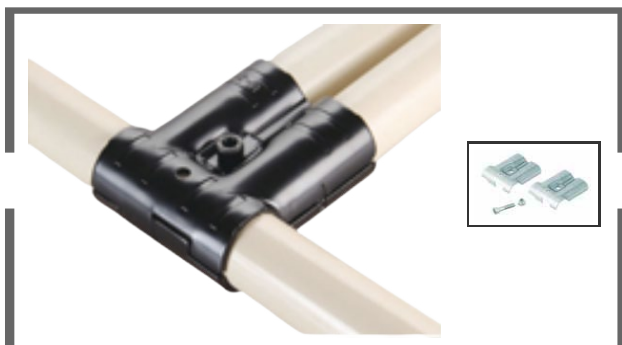

HJ-17



HJ-45



HJ-60



HJ-90

## METAL ACCESSORIES

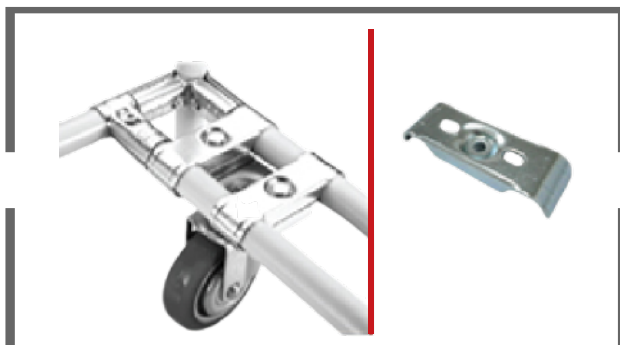

CM-100

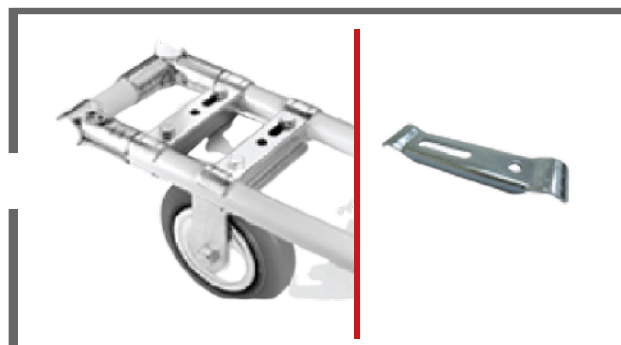

CM-200

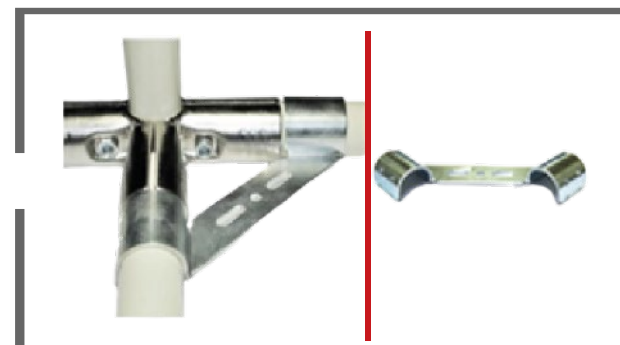

CM-A

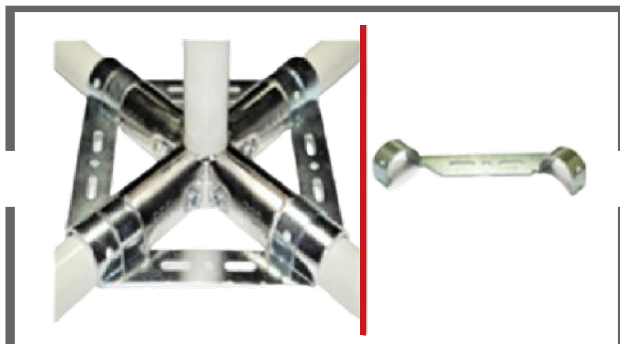

CM-B

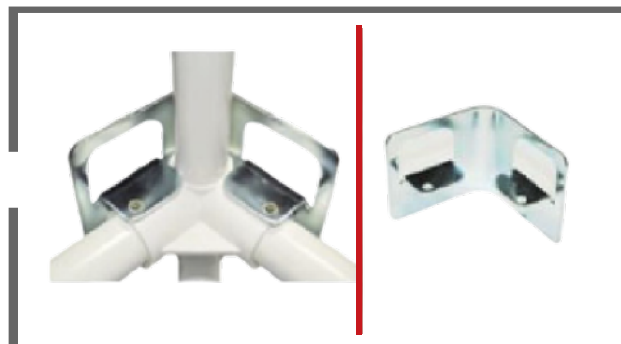

CM-C



TH-8L

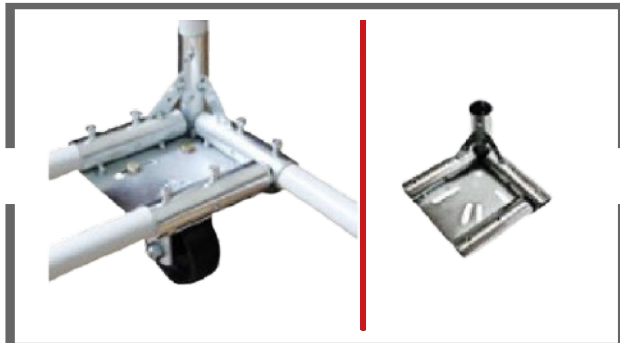

MCP-AL

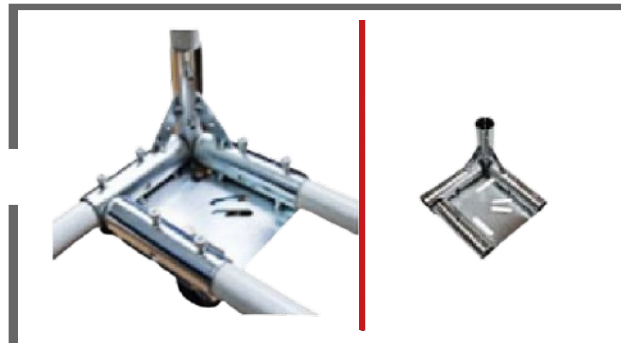

MCP-AR

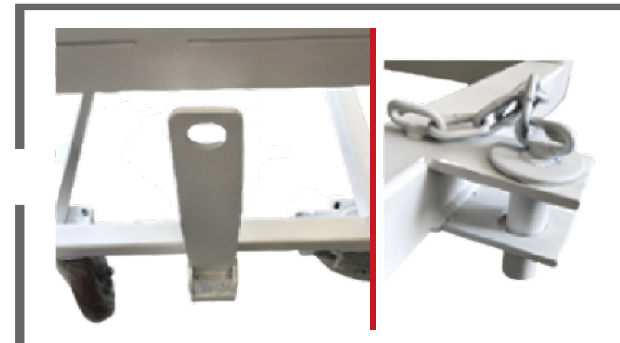

Tir-jal: Metal

## METAL ACCESSORIES



Tir-Jal: Tubular

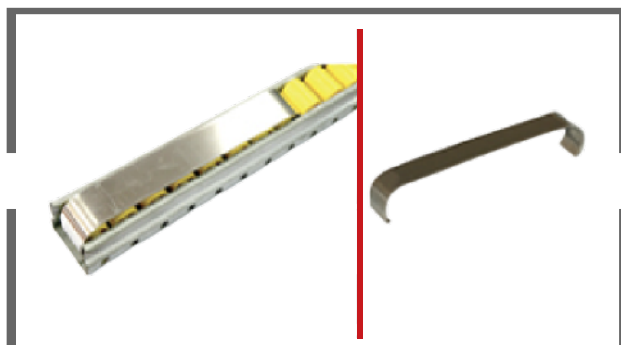

EWS-A

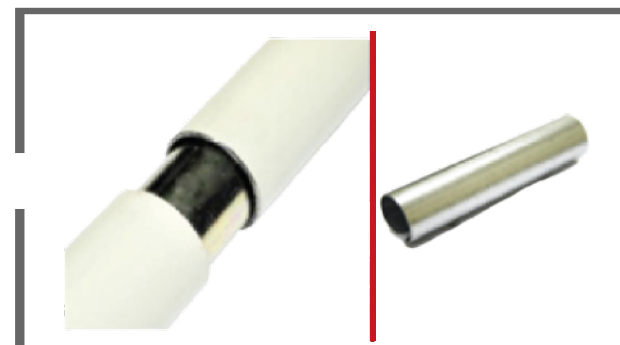

P-CON-A

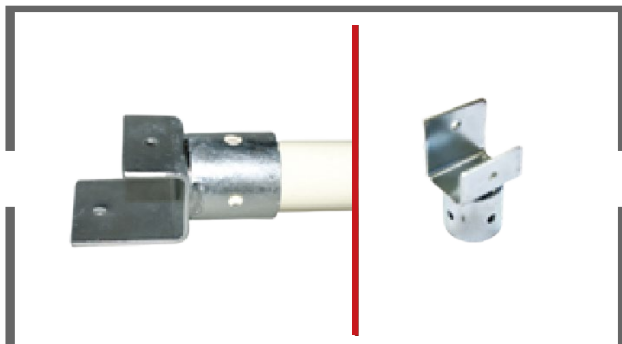

PR-A

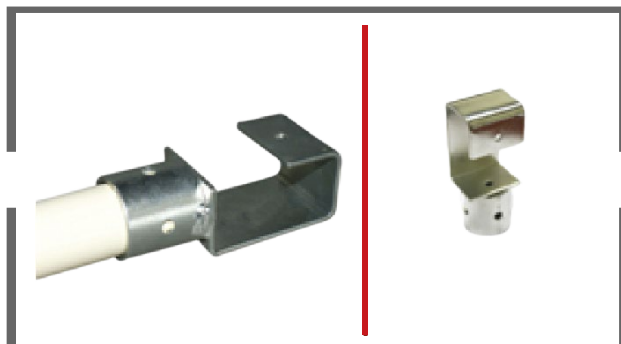

PR-B

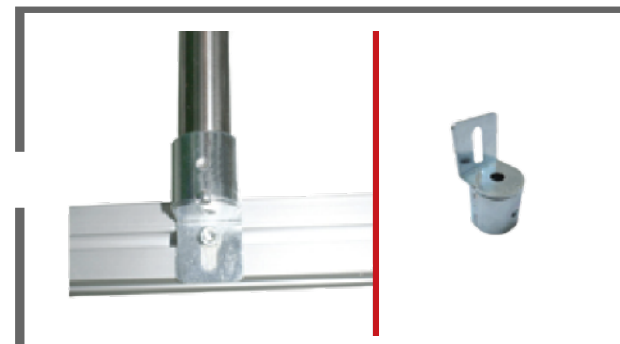

PR-L

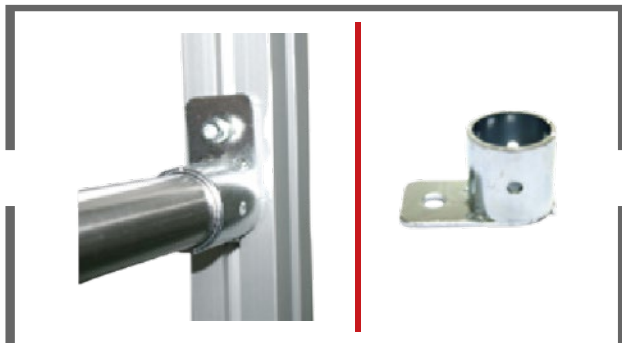

PR-S



SA



SA-S

Lean Manufacturing

Servicios & Fabricación

Sistema Tubular ALM

TELS. 442 962 0149 - 442 236 4457 - 442 205 9989

✉ [ventas@sistemasalm.com](mailto:ventas@sistemasalm.com) ✉ [alm@sistemasalm.com](mailto:alm@sistemasalm.com) ✉ [sistemasindustrialesalm@gmail.com](mailto:sistemasindustrialesalm@gmail.com)

[www.sistemasalm.com](http://www.sistemasalm.com)

## METAL ACCESSORIES

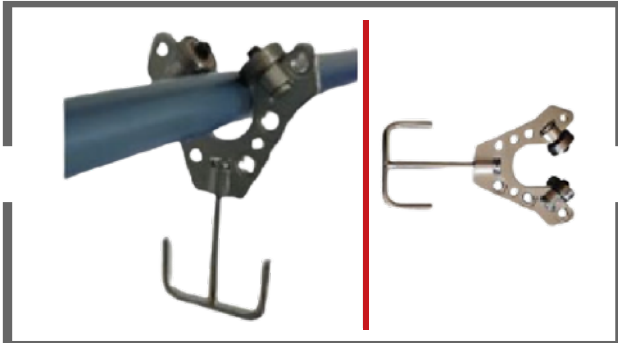

MR-2

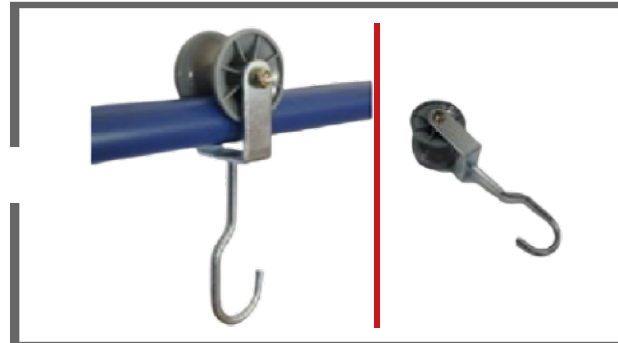

MR-3

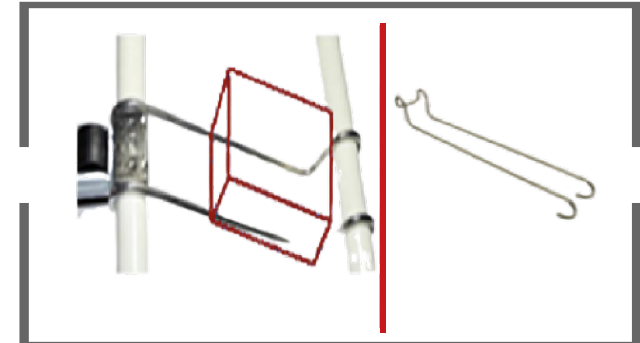

TB-300

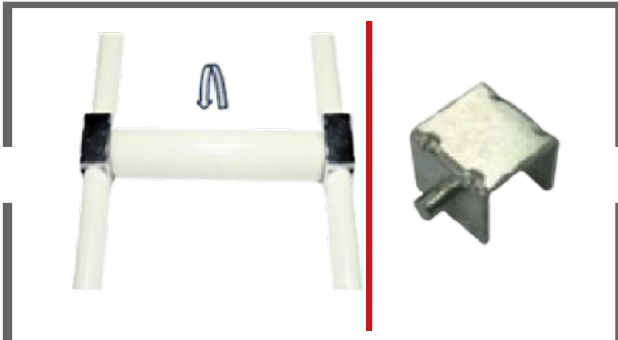

GS-RA

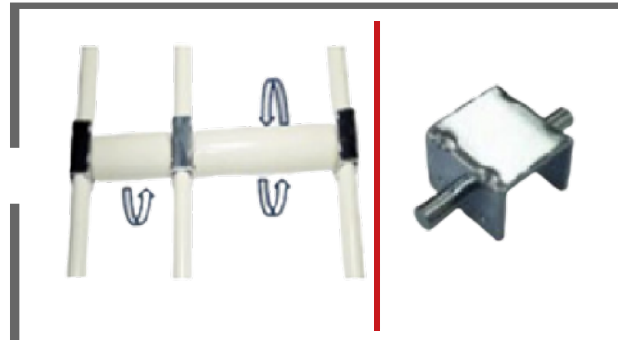

GS-RB

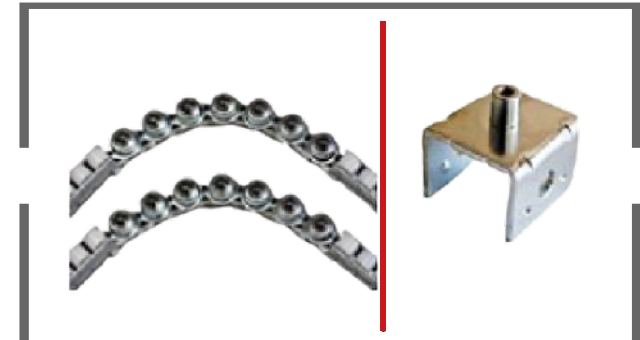

GS-RC



BT-1

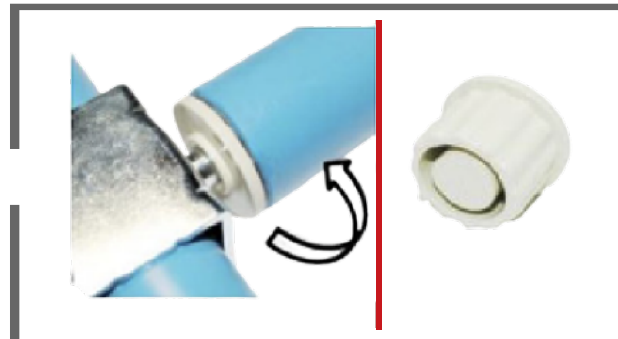

GAP-10A



GAP-12S

Lean Manufacturing

Servicios & Fabricación

Sistema Tubular ALM

TELS. 442 962 0149 - 442 236 4457 - 442 205 9989

✉ [ventas@sistemasalm.com](mailto:ventas@sistemasalm.com) ✉ [alm@sistemasalm.com](mailto:alm@sistemasalm.com) ✉ [sistemasindustrialesalm@gmail.com](mailto:sistemasindustrialesalm@gmail.com)

[www.sistemasalm.com](http://www.sistemasalm.com)

## BUSHINGS



BS-2810-A



BS-2810-B



AD-SM



AD-SMS

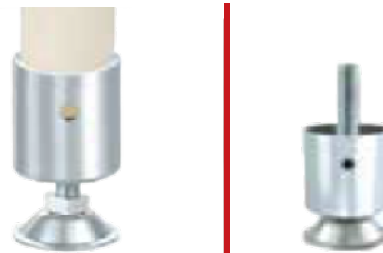

RL5



DA50



50 JUEGOS

KTT06B



RL8 Pata Redonda

Lean Manufacturing

Servicios & Fabricación

Sistema Tubular ALM

TELS. 442 962 0149 - 442 236 4457 - 442 205 9989

✉ [ventas@sistemasalm.com](mailto:ventas@sistemasalm.com) ✉ [alm@sistemasalm.com](mailto:alm@sistemasalm.com) ✉ [sistemasindustrialesalm@gmail.com](mailto:sistemasindustrialesalm@gmail.com)

[www.sistemasalm.com](http://www.sistemasalm.com)

## ROLLER TRACKS

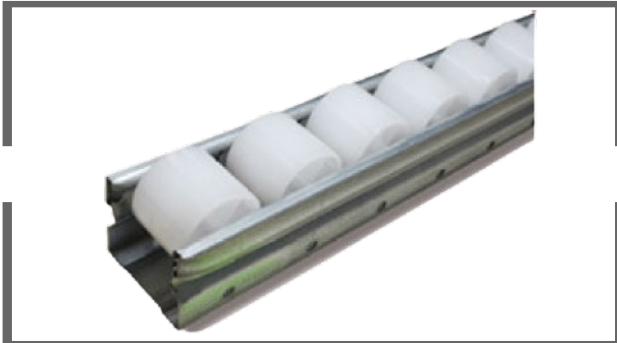

RT-40WH



RT-40BK

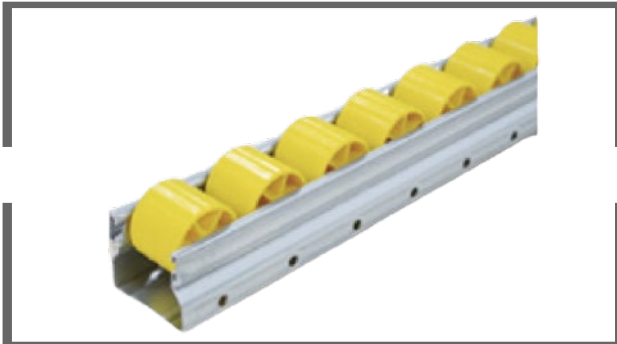

RT-4YE

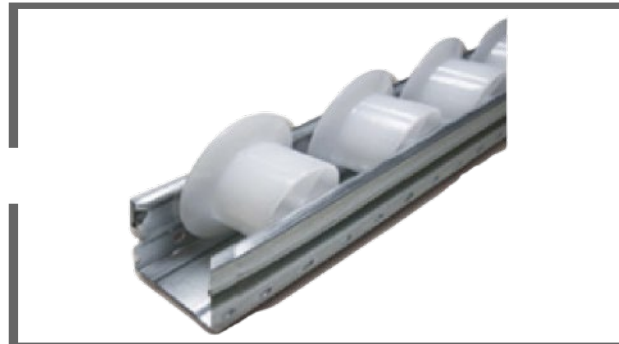

RT-40WHG

**STANDAR LENGTH = 4000MM**

**COLOR = WH, BK, YE.**

**LOAD CAPACITY = 150 KG.**

**ROLLER DIAMETER = 32 MM.**

**SHAFT DIAMETER = 4 MM.**

**ROLLER PITCH = 22 MM.**

**GALVANISED STEEL (SPCC) / PE**

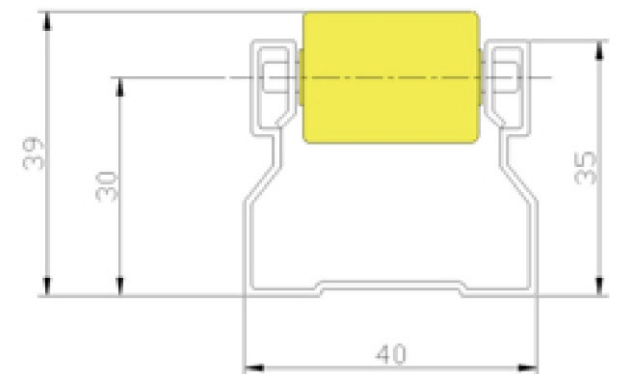

## MOUNTING BRACKETS

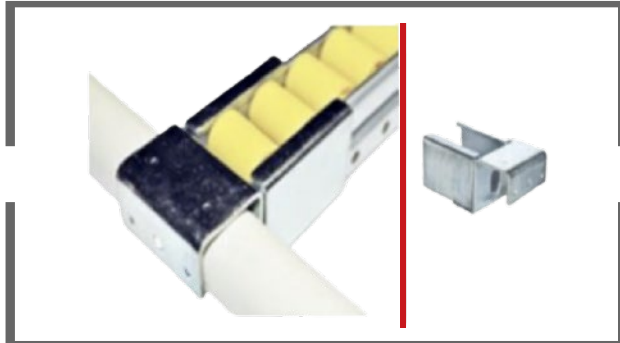

GP-A

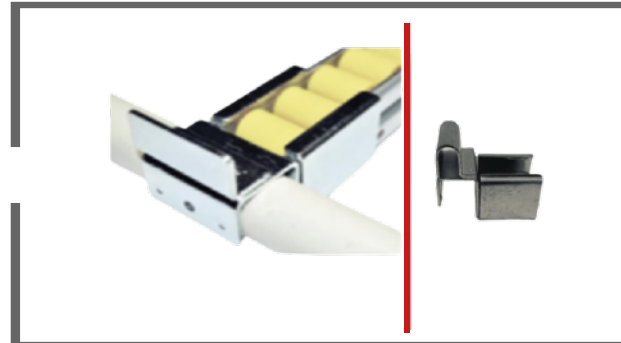

GP-B

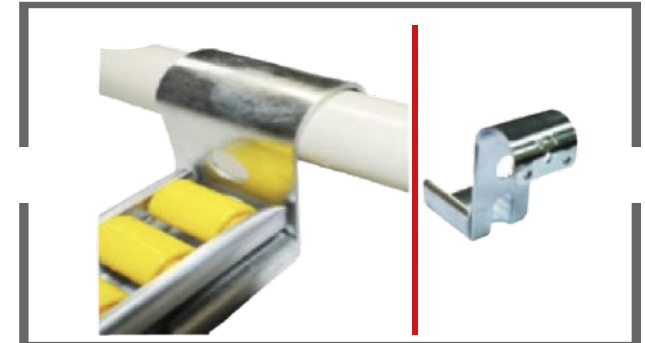

GP-D

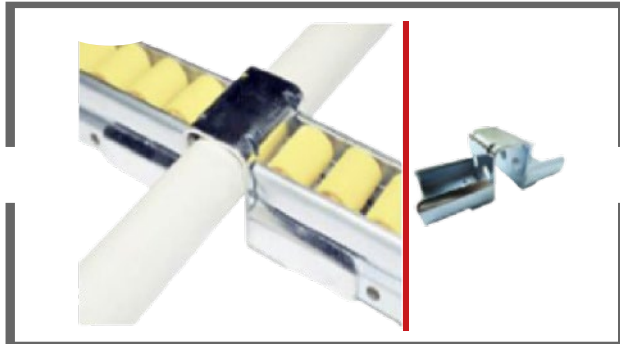

GP-H

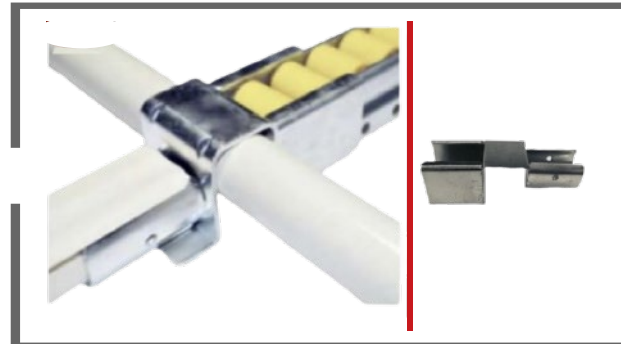

GP-J

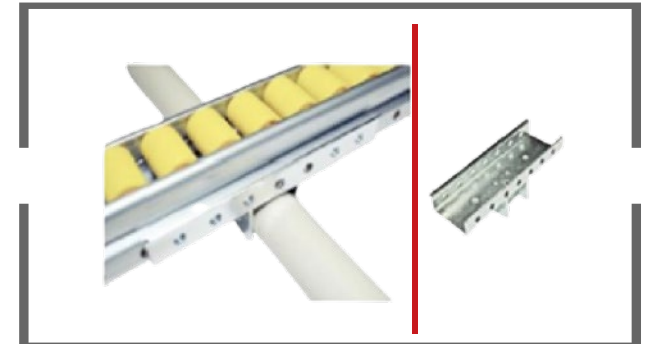

GP-C1

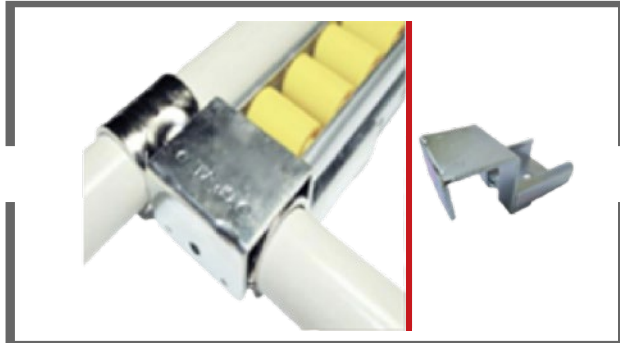

GP-AL

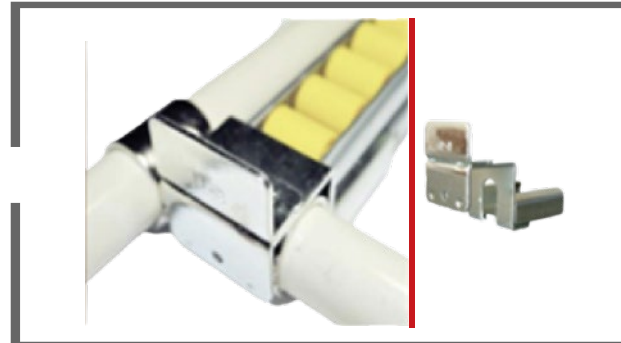

GP-BL

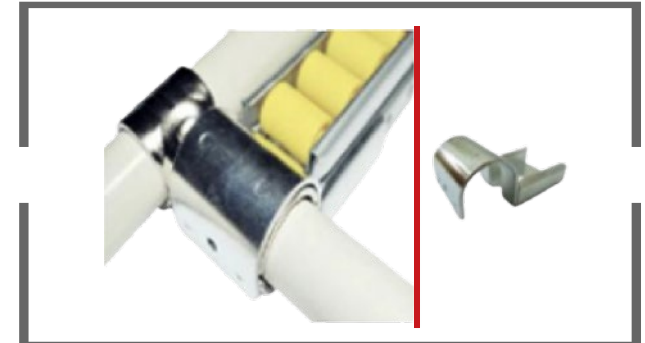

GP-ARL

# ALM



**SISTEMAS TUBULARES ALM**  
Advanced Lean Manufacturing  
[www.sistemasalm.com](http://www.sistemasalm.com)

SOLUCIONES PARA MEJORA CONTINUA

## MOUNTING BRACKETS

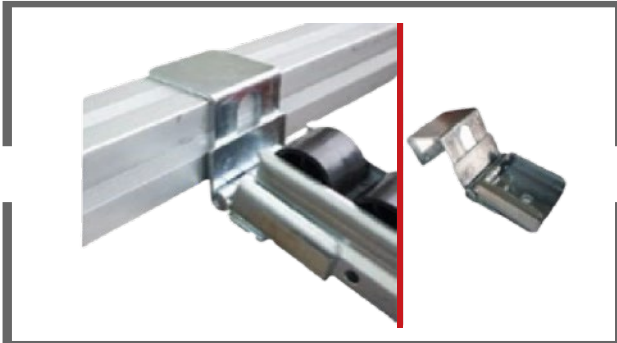

APL-M40A

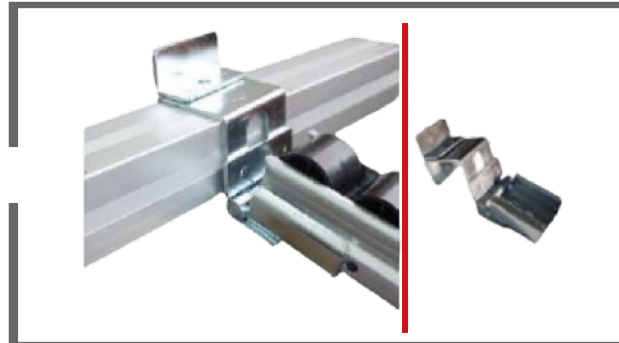

APL-M40B

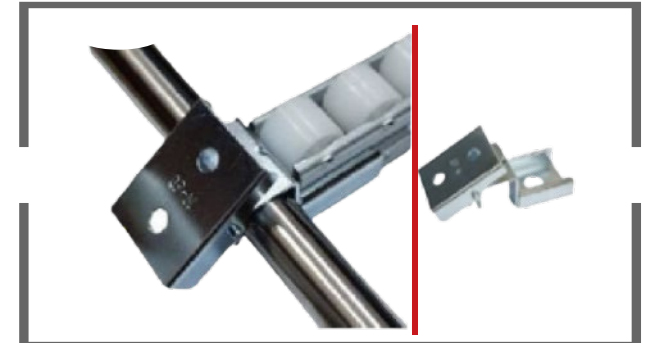

GP-M

Lean Manufacturing

Servicios & Fabricación

Sistema Tubular ALM

TELS. 442 962 0149 - 442 236 4457 - 442 205 9989

✉ [ventas@sistemasalm.com](mailto:ventas@sistemasalm.com) ✉ [alm@sistemasalm.com](mailto:alm@sistemasalm.com) ✉ [sistemasindustrialesalm@gmail.com](mailto:sistemasindustrialesalm@gmail.com)



[www.sistemasalm.com](http://www.sistemasalm.com)

## PVC & PLASTIC ACCESSORIES

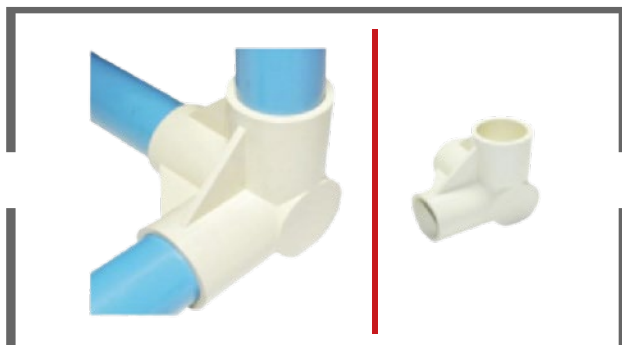

GAP-02A

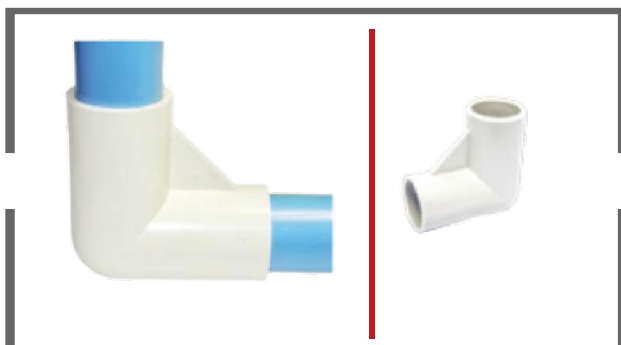

GAP-05

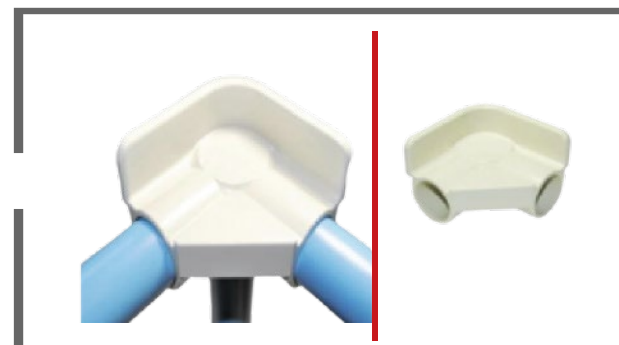

GAP-13

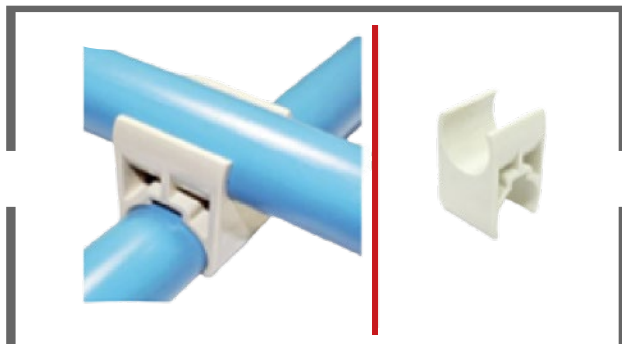

GAP-16

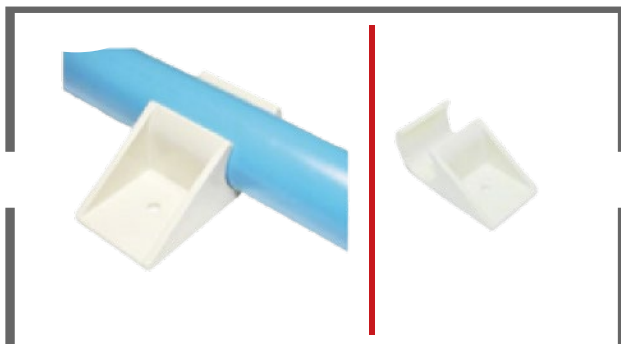

GAP-17

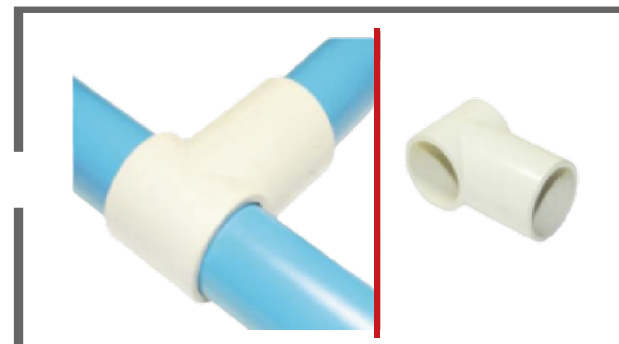

GAP-18

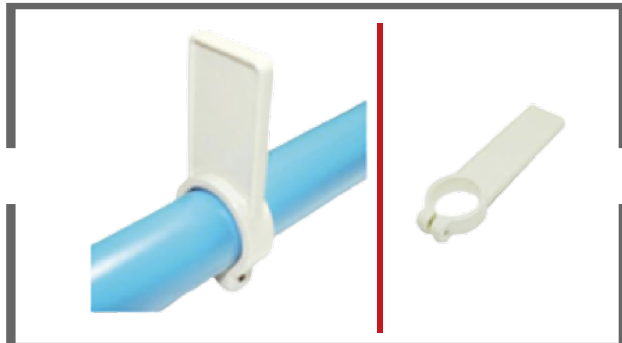

GAP-19A

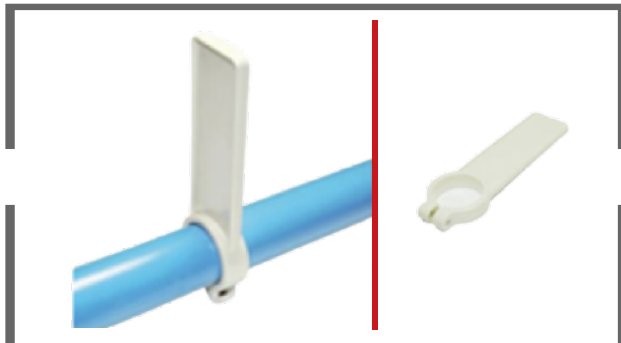

GAP-19B

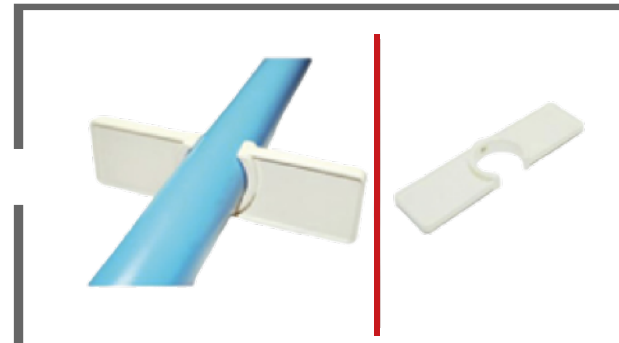

GAP-19C

## PVC & PLASTIC ACCESSORIES

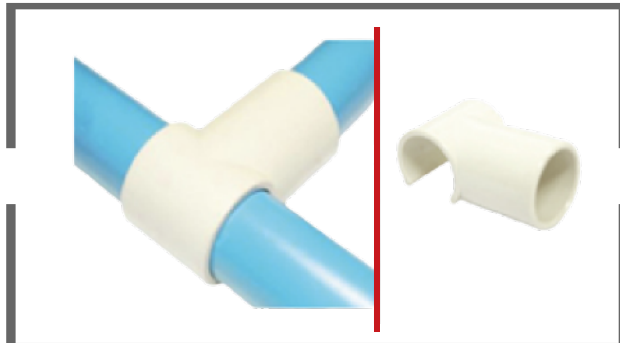

**GAP-20**

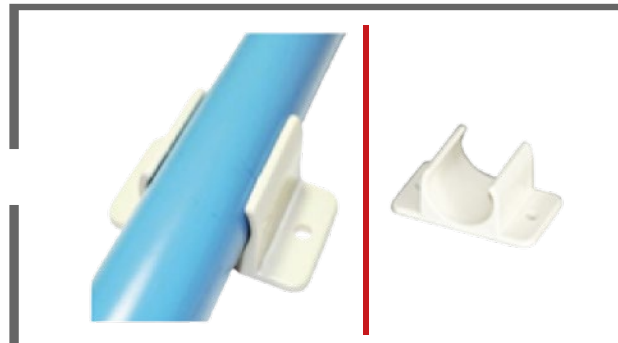

**GAP-49**

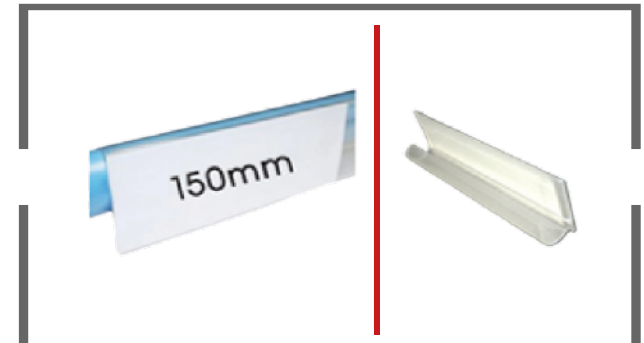

**NP-150**

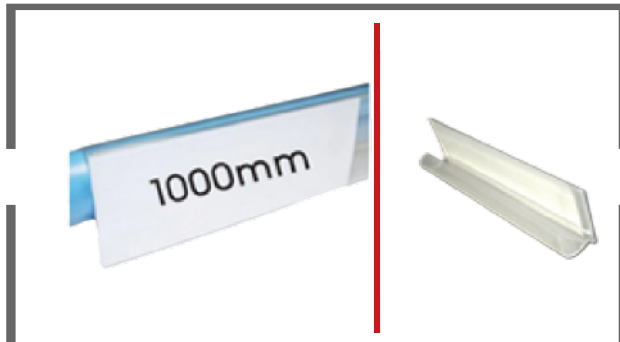

**NP-150**

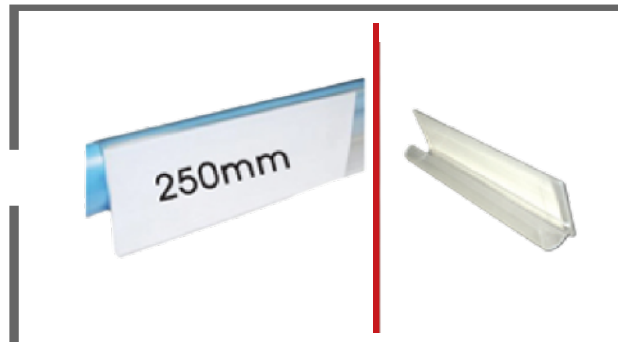

**NP-250**



**GAP-12 CAP**



**CAP-01 BK**



**CAP-03 IV**



**DPC14 3.0 mts.**

**RTG-3 4.0 mts.**

Lean Manufacturing

Servicios & Fabricación

Sistema Tubular ALM

TELS. 442 962 0149 - 442 236 4457 - 442 205 9989

✉ [ventas@sistemasalm.com](mailto:ventas@sistemasalm.com) ✉ [alm@sistemasalm.com](mailto:alm@sistemasalm.com) ✉ [sistemasindustrialesalm@gmail.com](mailto:sistemasindustrialesalm@gmail.com)



[www.sistemasalm.com](http://www.sistemasalm.com)

# ALM



**SISTEMAS TUBULARES ALM**  
Advanced Lean Manufacturing  
[www.sistemasalm.com](http://www.sistemasalm.com)

SOLUCIONES PARA MEJORA CONTINUA

## PVC & PLASTIC ACCESSORIES

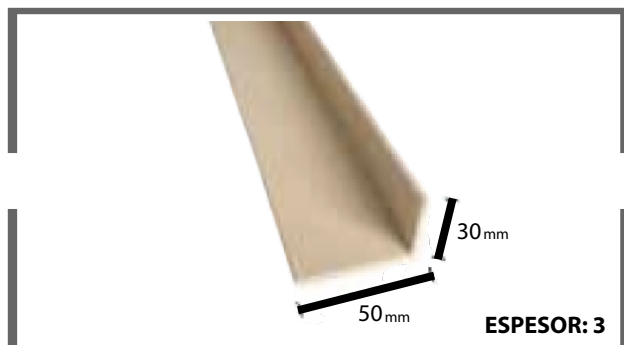

**DPC1**

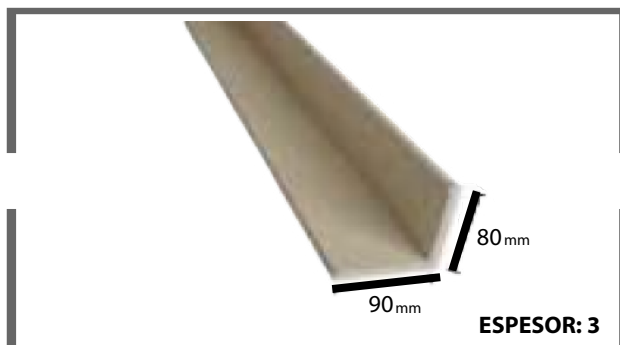

**DPC3**

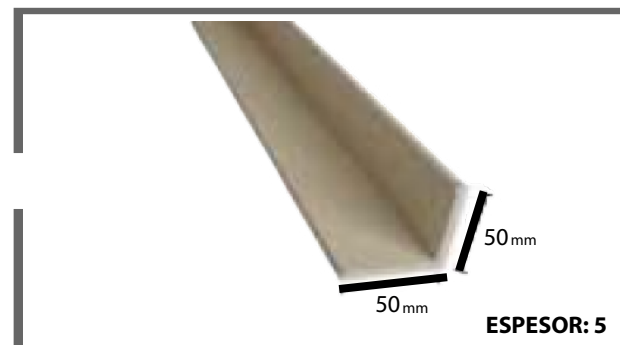

**DPC5**

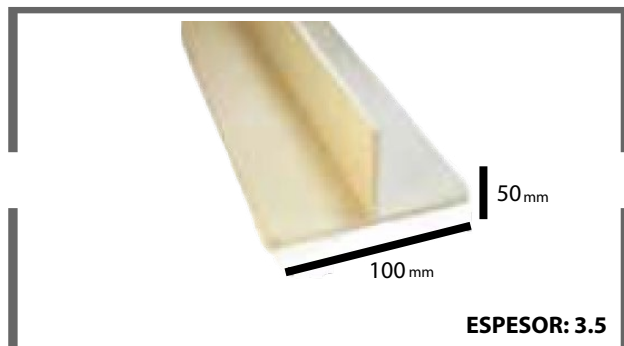

**DPC9A**

Lean Manufacturing

Servicios & Fabricación

Sistema Tubular ALM

TELS. 442 962 0149 - 442 236 4457 - 442 205 9989

✉ [ventas@sistemasalm.com](mailto:ventas@sistemasalm.com) ✉ [alm@sistemasalm.com](mailto:alm@sistemasalm.com) ✉ [sistemasindustrialesalm@gmail.com](mailto:sistemasindustrialesalm@gmail.com)



[www.sistemasalm.com](http://www.sistemasalm.com)



**ALM**

**ALLUMINIUM  
PIPE SYSTEM**

## ALLUMINIUM PIPE SYSTEM



A-1



A-2



A-3



A-4

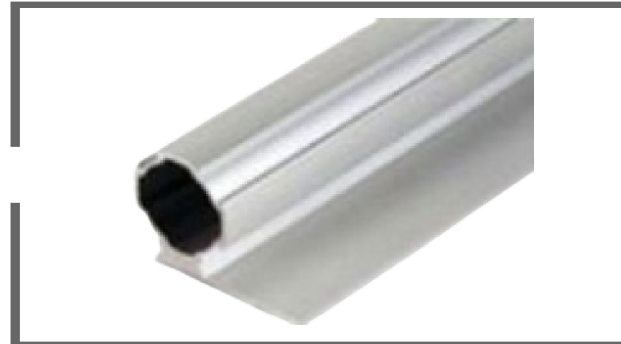

A-5



A-H1



A-H2



A-H3



A-H4

Lean Manufacturing

Servicios & Fabricación

Sistema Tubular ALM

TELS. 442 962 0149 - 442 236 4457 - 442 205 9989

✉ [ventas@sistemasalm.com](mailto:ventas@sistemasalm.com) ✉ [alm@sistemasalm.com](mailto:alm@sistemasalm.com) ✉ [sistemasindustrialesalm@gmail.com](mailto:sistemasindustrialesalm@gmail.com)

# ALM



**SISTEMAS TUBULARES ALM**  
Advanced Lean Manufacturing  
[www.sistemasalm.com](http://www.sistemasalm.com)

SOLUCIONES PARA MEJORA CONTINUA

## ALLUMINIUM PIPE SYSTEM



A-H5



A-H6

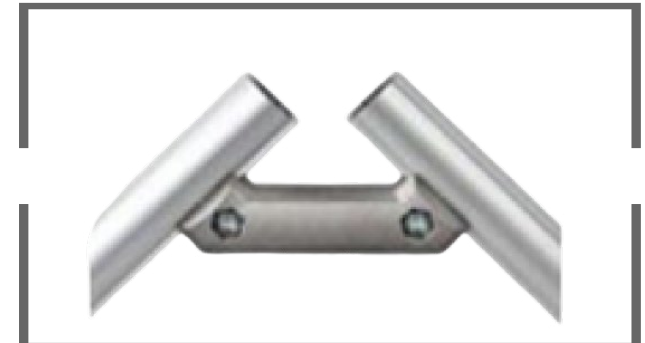

A-H7



A-H8



AP-1 Tapón



A-P2



ALLUP-12G Inserto

Lean Manufacturing

Servicios & Fabricación

Sistema Tubular ALM

TELS. 442 962 0149 - 442 236 4457 - 442 205 9989

✉ [ventas@sistemasalm.com](mailto:ventas@sistemasalm.com) ✉ [alm@sistemasalm.com](mailto:alm@sistemasalm.com) ✉ [sistemasindustrialesalm@gmail.com](mailto:sistemasindustrialesalm@gmail.com)

[www.sistemasalm.com](http://www.sistemasalm.com)





**ALM**

**CASTERS**

## CASTERS

**95-GURY150TL**

**TOTAL LOCK GIRATORIA**

**94-GURY150TL**

**TOP PLATE FIJA**

SHOCK ABSORBER  
CASTER

**6" X 2"**

POLIURETANO CON  
RIN DE ACERO  
RESORTES ALTA  
RESISTENCIA  
HERRAJE DE ACERO  
REFORZADO

LOAD CAPACITY 350 KG COLOR RED



SHOCK ABSORBER  
CASTER

**6" X 2"**

POLIURETANO CON  
RIN DE ACERO  
RESORTES ALTA  
RESISTENCIA  
HERRAJE DE ACERO  
REFORZADO

LOAD CAPACITY 350 KG COLOR RED



**271URY075T12**

**SWIVEL VASTAGO 1/2"**

**273URY075T12**

**TOTAL BRAKE VASTAGO 1/2"**

STEM SWIVEL  
CASTER

**3" X 1 1/4"**

POLIURETANO  
DOBLE BALERO  
PRECISIÓN  
SIN MARCAS EN EL  
PISO

LOAD CAPACITY 90 KG COLOR RED



STEM SWIVEL  
CASTER

**3" X 1 1/4"**

POLIURETANO  
DOBLE BALERO  
PRECISIÓN  
SIN MARCAS EN EL  
PISO

LOAD CAPACITY 90 KG COLOR RED



## CASTERS

**271URY100T12**

STEM SWIVEL  
CASTER

4" X 1 1/4"

POLIURETANO  
DOBLE BALERO  
PRECISIÓN  
SIN MARCAS EN EL  
PISO

**SWIVEL VASTAGO 1/2"**

LOAD CAPACITY 100 KG COLOR RED



**273URY100T12**

STEM SWIVEL  
CASTER

4" X 1 1/4"

POLIURETANO  
DOBLE BALERO  
PRECISIÓN  
SIN MARCAS EN EL  
PISO

**TOTAL BRAKE VASTAGO 1/2"**

LOAD CAPACITY 100 KG COLOR RED



**274URY075TPL**

TOP PLATE  
CASTER

3" X 1 1/4"

POLIURETANO  
DOBLE BALERO  
PRECISIÓN  
RODAJE CON  
PLACA BASE

**TOTAL BRAKE GIRATORIA**

LOAD CAPACITY 100 KG COLOR RED



**274URR075TPL**

TOP PLATE  
CASTER

3" X 1 1/4"

POLIURETANO  
DOBLE BALERO  
PRECISIÓN  
RODAJE CON  
PLACA BASE

**TOP PLATE FIJA**

LOAD CAPACITY 100 KG COLOR RED



# ALM



SOLUCIONES PARA MEJORA CONTINUA

**SISTEMAS TUBULARES ALM**  
Advanced Lean Manufacturing  
[www.sistemasalm.com](http://www.sistemasalm.com)

## CASTERS

**274URY100TPL**

**TOTAL BRAKE GIRATORIA**

**274URR100TPL**

**TOP PLATE FIJA**

**LOAD CAPACITY 110 KG    COLOR RED**

**LOAD CAPACITY 110 KG    COLOR RED**

TOP PLATE  
CASTER

**4" X 1 1/4"**

POLIURETANO  
DOBLE BALERO  
PRECISIÓN  
RODAJE CON  
PLACA BASE



TOP PLATE  
CASTER

**4" X 1 1/4"**

POLIURETANO  
DOBLE BALERO  
PRECISIÓN  
RODAJE CON  
PLACA BASE



Lean Manufacturing

Servicios & Fabricación

Sistema Tubular ALM



TELS. 442 962 0149 - 442 236 4457 - 442 205 9989

✉ [ventas@sistemasalm.com](mailto:ventas@sistemasalm.com) ✉ [alm@sistemasalm.com](mailto:alm@sistemasalm.com) ✉ [sistemasindustrialesalm@gmail.com](mailto:sistemasindustrialesalm@gmail.com)

[www.sistemasalm.com](http://www.sistemasalm.com)

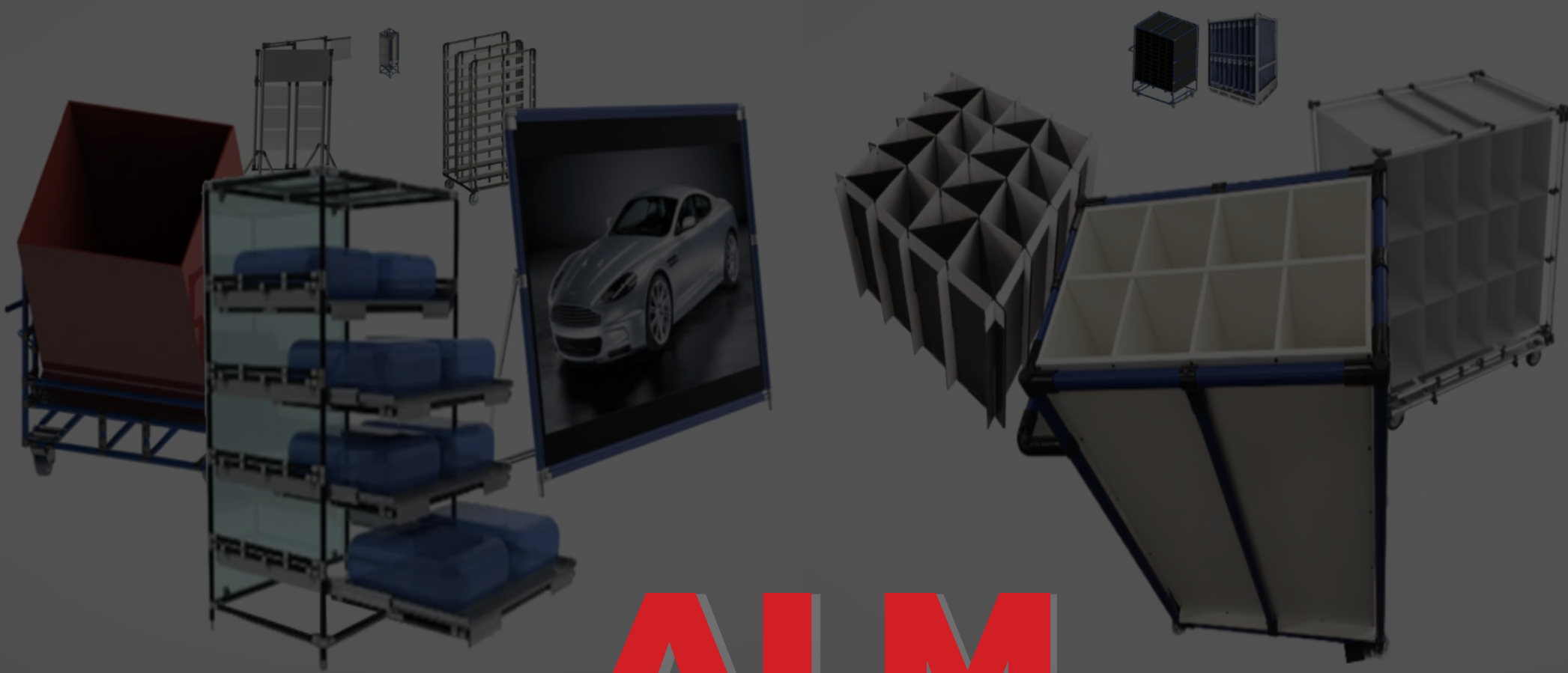

**ALM**



**CATÁLOGO DE APLICACIONES**

# ALM



## SISTEMAS TUBULARES ALM

Advanced Lean Manufacturing

[www.sistemasalm.com](http://www.sistemasalm.com)

SOLUCIONES PARA MEJORA CONTINUA

## CATÁLOGO DE APLICACIONES



Lean Manufacturing

Servicios & Fabricación

Sistema Tubular ALM

TELS. 442 962 0149 - 442 236 4457 - 442 205 9989

✉ [ventas@sistemasalm.com](mailto:ventas@sistemasalm.com) ✉ [alm@sistemasalm.com](mailto:alm@sistemasalm.com) ✉ [sistemasindustrialesalm@gmail.com](mailto:sistemasindustrialesalm@gmail.com)

[www.sistemasalm.com](http://www.sistemasalm.com)



# ALM



**SISTEMAS TUBULARES ALM**  
Advanced Lean Manufacturing  
[www.sistemasalm.com](http://www.sistemasalm.com)

## CATÁLOGO DE APLICACIONES

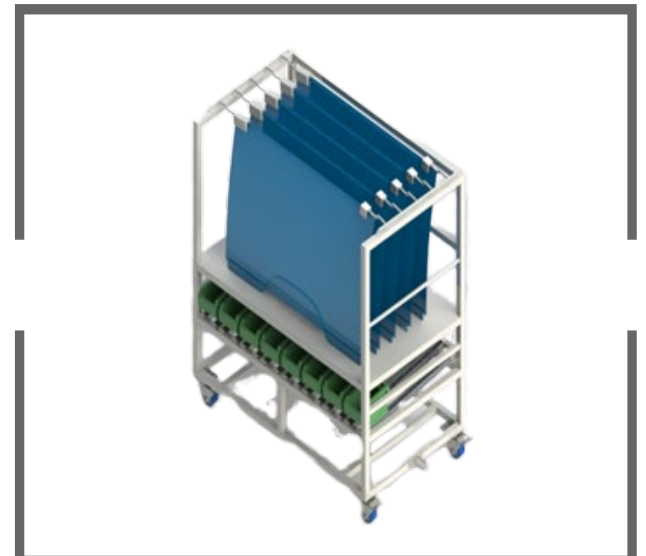

Lean Manufacturing

Servicios & Fabricación

Sistema Tubular ALM

TELS. 442 962 0149 - 442 236 4457 - 442 205 9989

✉ [ventas@sistemasalm.com](mailto:ventas@sistemasalm.com) ✉ [alm@sistemasalm.com](mailto:alm@sistemasalm.com) ✉ [sistemasindustrialesalm@gmail.com](mailto:sistemasindustrialesalm@gmail.com)

[www.sistemasalm.com](http://www.sistemasalm.com)



### FICHA TÉCNICA

#### CAPACIDAD DE CARGA DEL TUBO

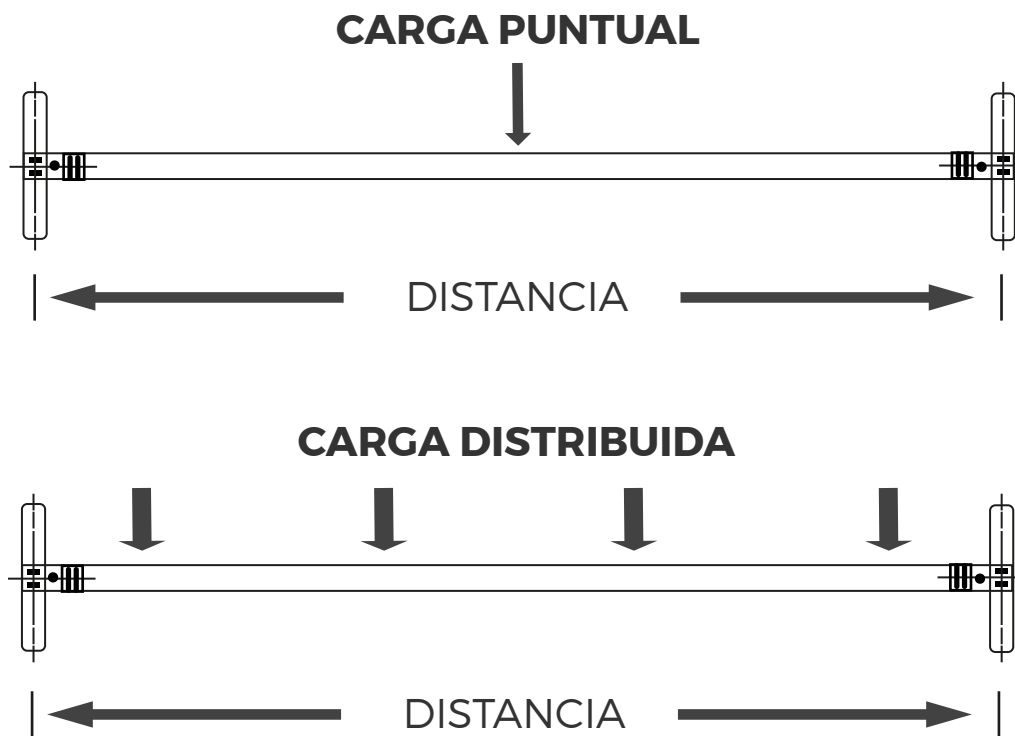

**TUBO DND 0.9mm ESPESOR CARGA MÁXIMA**

DISTANCIA	C PUNTUAL	C DISTRIBUCIÓN
mm	kg.	kg.
205	221	441
405	112	221
605	75	148
805	57	112
1005	46	90
1205	39	75
1405	33	65
1605	29	57
1805	26	51

### FICHA TÉCNICA

#### RESISTENCIA A LA FLEXIÓN DE RIEL CON RUEDA

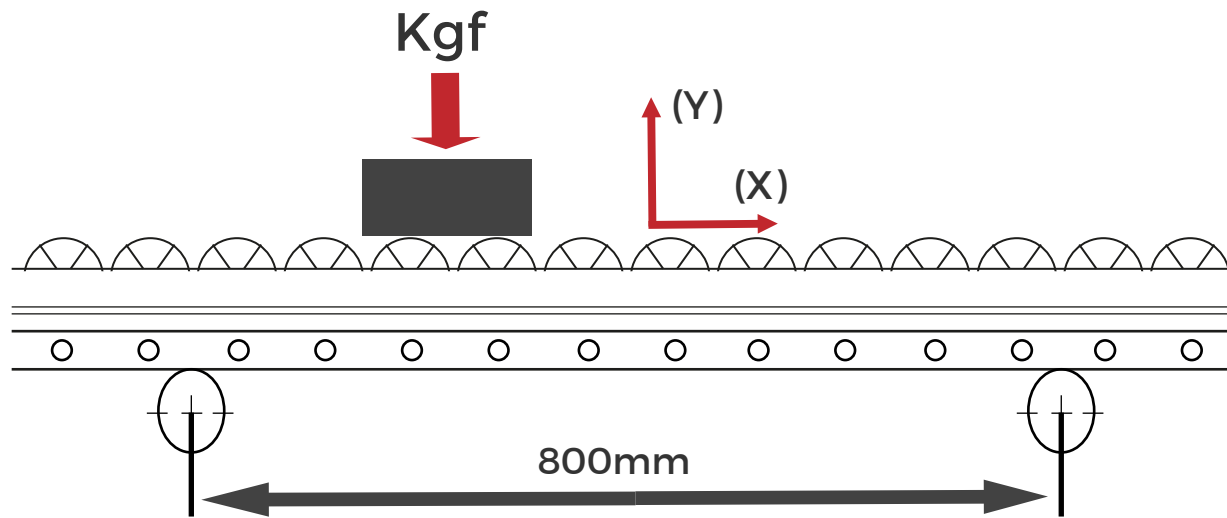

**LONGITUD DE CENTRO A CENTRO (800 mm)**

UNIT: kgf

**PWC-40A**

185

# ALM

SOLUCIONES PARA MEJORA CONTINUA

SISTEMAS TUBULARES ALM

Advanced Lean Manufacturing

[www.sistemasalm.com](http://www.sistemasalm.com)



TELS. 442 962 0149 - 442 236 4457 - 442 205 9989

✉ [ventas@sistemasalm.com](mailto:ventas@sistemasalm.com) ✉ [alm@sistemasalm.com](mailto:alm@sistemasalm.com) ✉ [sistemasindustrialesalm@gmail.com](mailto:sistemasindustrialesalm@gmail.com)